



Ocean Sensor Systems

Data Logger, OSSI-012-015

General Description

The OSSI-012-015 Data Logger is designed to take synchronous samples from our wired and wireless sensors. It can also log Analog Voltages and Generic Serial Data. Synchronized Sampled Data is time tagged and stored on a SD memory card. The Memory Card is easily removed and can be read on any PC using a standard SD Memory Card Reader. The data may then be displayed and analyzed with the new version OSSI Interface Program. Sample Data may also be streamed out to a PC using the RS232/485 port or the optional 1-watt RF modem.

Features

- Log Data from our Wired and Wireless Sensors
- Log Analog Voltages and Generic Serial Data
- SD Memory card for Logged Data
- Dual Power input for Battery Packs, Solar Power or AC/DC Adapter Power
- Synchronous sample Data with Time Stamp
- Accurate Real Time Clock ± 2 ppm
- GPS Clock Update with Time
- Data Streaming via RS232 or RS485
- Data Streaming via Opt. 1Watt Wireless Modem
- Continuous or Burst sampling Operation
- Sample Rate Up to 32Hz
- Configure, Display & Analyze with new version 3 Staff and Sonic Interface Program
- Rugged Sealed Waterproof Case NEMA 4X for remote isolated locations.

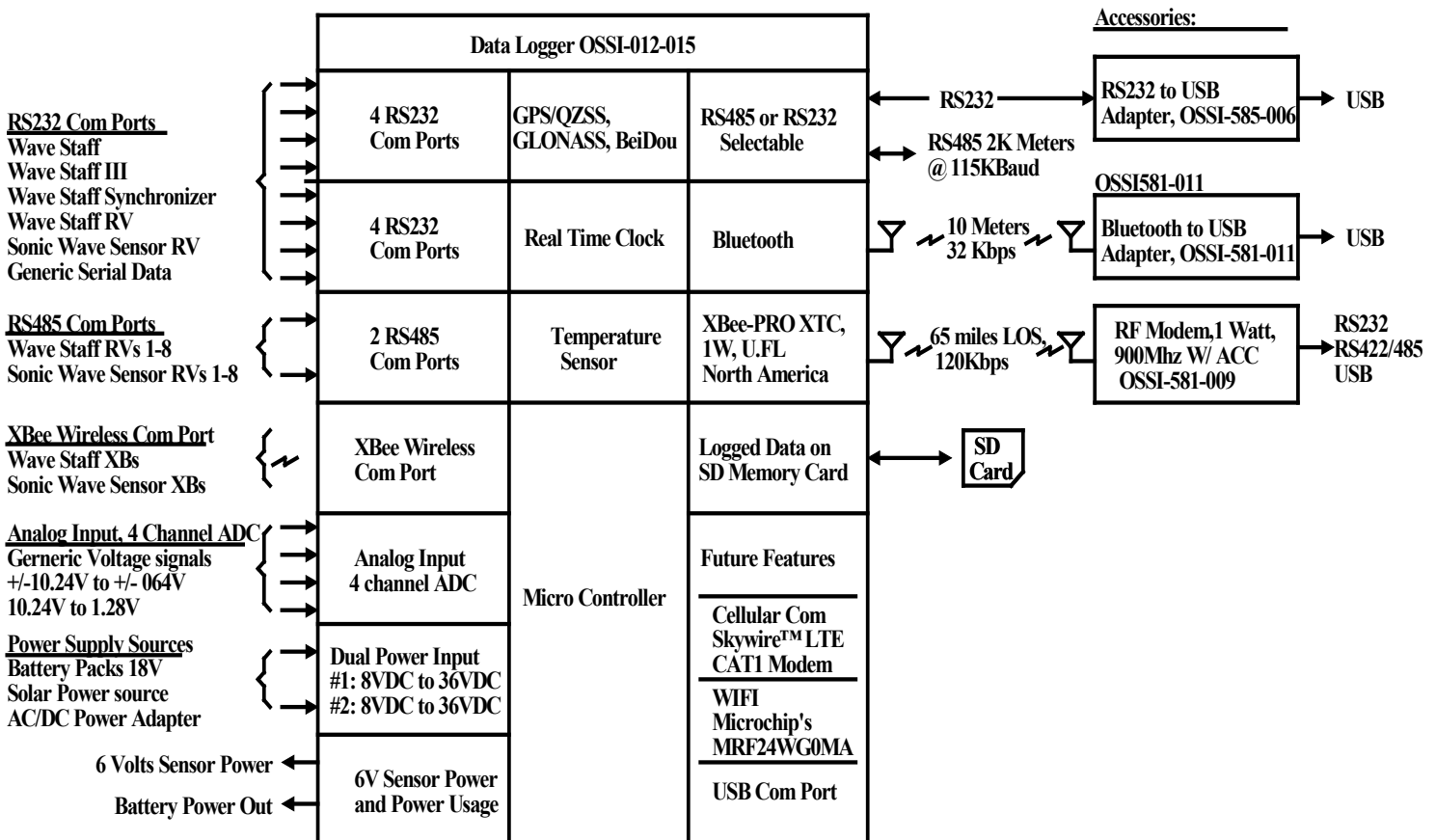

Dimensions and Ordering Information

Part Number	Option
OSSI-012-015	None
OSSI-012-015X	XBee Pro 1watt Modem and X-Tend-PKG Adapter OSSI-581-009 65 mile LOS, 900 MHz



Enclosures Hinged Polyester
Type 4X UV Resistant
Approximate Size 4"x8"x8"
For detailed dimensions see Hoffman P/N A884PHC.



Inside Data Logger Enclosure

Included Accessories:



1 each OSSI-584-006
SD Flash Memory Card 32G



1 each OSSI-585-007
 USB to RS232 Adapter with PL2303 Chipset,
 Cable Creation Part Number CD0493
 USB to DB9 Serial Converter for Windows 10, 8.1, 8, 7, Vista, XP, 2000



6 each OSSI-692-001
 6 Cable Gland w/Nut, 3/8 NPT, 4.6 mm, 7.9 mm, Nylon 6.6 (Polyamide 6.6), Grey



2 each OSSI-015-019
 18V Battery packs 12 C-cells in series

Included with part number OSSI-012-015X



Option X: 1Watt Wireless Modem
 MODEM RF 900MHZ 1W USB W/ ACC
 Digi Part number XT09-PKC-UA

Optional Accessories:



OSSI-596-003
 2.5W Continuous Remote Power System.
 10W integrated Solar Panel. Die Cast Aluminum Enclosure.
 12V 9Ah Battery
 Tycon Systems RPDC12-9-10



OSSI-581-012
Laird - Wireless & Thermal Systems BT900-US
RF 2.4GHz ~ 2.48GHz Bluetooth v4.0, Low Energy (BLE) USB 3Mbps

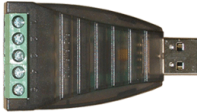

OSSI-585-005
Industrial grade mini *RS485 / RS422 to USB converter*

The Data Logger's Sensor Input Ports:

Analog Input #1 to #4:

Programable ranges +/-10.24V to +/-0.64V and 10.24V to 1.28V

Wiring, J1 to J4:

Pin 1 B+ Source from Battery input voltage and current limited with 1 amp. fuse.

Pin 2 +6V with 3 amp. Current limiting.

Pin 3 +ANA is the + Analog input

Pin 4 AGND is the Analog Common input, 0 volts.

Pin 5 PGND is the Power Ground.

RS232 Sensor Input #1 to #8:

Auto Connect to Wave Staffs, Wave Staff IIIs, Wave Staff Synchronizers, Wave Staff RVs, Sonic Wave Sensor RVs and Generic Serial Data.

Wiring, J5 to J12:

Pin 1 B+ Source from Battery input voltage and current limited with 1 amp. fuse.

Pin 2 +6V with 3 amp. Current limiting.

Pin 3 RX RS232 Transmit output to sensor.

Pin 4 RX RS232 Receive input from sensor.

Pin 5 PGND Power ground (0 volt).

Typical Wiring example, Wave Staff to RS232 port:

Pin 1 B+ = no connection

Pin 2 +6V = Wave Staff Red wire.

Pin 3 TX = Wave Staff Green wire.

Pin 4 RX = Wave Staff Orange wire.

Pin 5 PGND = Wave Staff Black wire.

RS485 Sensor Input #1 to #2:

Auto Connect to Wave Staff RVs and Sonic Wave Sensor RVs.

Wiring, J13 to J14:

Pin 1 B+ Source from Battery input voltage and current limited with 1 amp. fuse.

Pin 2 +6V with 3 amp. Current limiting.

Pin 3 D+ RS485 + Transceiver line

Pin 4 D- RS485 – Transceiver line

Pin 5 PGND Power ground (0 volt)

XBee / XBee Pro Wireless Sensor Input:

Auto connect to Wave Staff XBs and Sonic Wave Sensors

Device number must be preset from 1 to 99

Communication Output Ports:

For Data Streaming and Configuring

RS232 Port Wiring, J15 DB9 connector if RS232 selected:

Pin 2 = PCs RX, the connecting computer's receive pin

Pin 3 = PCs TX, the connecting computer's transmit pin

Pin 5 =GND Ground

RS485 Port Wiring, J16 if RS485 selected:

Pin 1 B+ Source from Battery input voltage and current limited with 1 amp. fuse.

Pin 2 +6V with 3 amp. Current limiting.

Pin 3 D+ RS485 + Transceiver line

Pin 4 D- RS485 – Transceiver line

Pin 5 PGND Power ground (0 volt)

Wireless Modem 1watt RF Modem 900MHZ:

When option X ordered.

Digi International XBP9XT-DMUS-001

Wireless Bluetooth:

Bluetooth version 4.0 (BR/EDR/LE) module,

Microchip RN4677

GPS:

For real time clock update

U-bolx CAM-M8C

Dual Power Input:

Voltage range: 8VDC to 36VDC

Reverse Polarity Protection Smart Diode Ored

Power Usages depends on the configuration with sensors etc.

See the actual Power Usages with the PC interface program.

Power output:

+6V Power

Voltage 6 Volts +/- 2%

Current Limited at 3 amps.

On/Off in burst mode

+Bat Power

Equal to highest Power Input voltage.

Replaceable fused, 1 amp.

User Interface Software:

A new version 3.0, Staff and OSSI Interface Program is available to download from our web site. We recommend using the program to configure the Data Logger for your requirements. It can also be used to display and analyze streaming wave data and Logged SD card files. Sampled data can be saved to a file for future analysis with the OSSI Interface Program or other analysis software.

The following information is for reference and is not needed when the OSSI Interface Program is used.

The serial Real Time Data Output and the SD Flash Card both use the same frame format. It is an API Frame, Type 0x90E with Escape Characters.

SD Flash Card Data Files:

Number of Files and File Name:

A new directory will be created each time the power is cycled, or the flash card is replaced. The maximum number of new files in the directory is 9999, 1 per day or less. The file names are automatically created starting at DLOG0001 and sequenced up to DLOG9999. The file extension is .DAT.

File Format:

A File Header is placed at the start of each file when created. The Header contains the Data Logger version, Part number, Serial #, time, date and configuration information. Each line starts with a blank space and the last line ends with an additional carriage return line feed.

Example File Header:

Data Logger Ver,1,
 Part #,OSSI-012-015P
 Serial #,17-05-25-001
 Date & Time,2019-10-09T10:51:51
 Burst Length,Continuous
 Burst Interval,3,Min.
 New File Interval,Continuous

Data Format:**SD Flash Card Data and Serial Output Frame Format****API Frame Type 0x90**

API Operation - with Escape Characters (AP parameter = 2):

Escape characters. When sending or receiving a data frame, specific data values must be escaped (flagged) so they do not interfere with the data frame sequencing. To escape an interfering data byte, insert 0x7D and follow it with the byte to be escaped XOR'd with 0x20. Data bytes that need to be escaped: 0x7E – Frame Delimiter, 0x7D – Escape, 0x11 – XON, 0x13 – XOFF

Checksum:

To test data integrity, a checksum is calculated and verified on non-escaped data.

To calculate: Not including frame delimiters and length, add all bytes keeping only the lowest 8 bits of the result and subtract the result from 0xFF.

To verify: Add all bytes (include checksum, but not the delimiter and length). If the checksum is correct, the sum will equal 0xFF.

Sample Data from all Sensors - Data Type (F) 4-byte Float - Little Endian. 32 samples per frame

	Frame Fields		Offset	Example	Description	
API Packet	Start Delimiter		0	0x7E		
	Length		MSB 1	0x00	Number of bytes between the length and the checksum	
			LSB 2	0xEF		
	Frame - specific Data	Frame Type		3	0x90	
		64-bit Source Address		MSB 4	0x05	64-bit address of sender. Set to 0xFFFFFFFFFFFFFFFF (unknown 64-bit address) if the sender's 64-bit address is unknown.
				5	0x51	
				6	0xBA	
				7	0x5E	
				8	0x16	
				9	0x09	
				10	0x14	
				LSB 11	0x01	
				16-bit Source Network Address		
LSB 13		0x41				

		Receive Options	14	0x01	0x01 - Packet Acknowledged 0x02 - Packet was a broadcast packet 0x20 - Packet encrypted with APS encryption 0x40 - Packet was sent from an end device (if known)
	Received Sensor Data	Source Data Type (ASCII)	15	F	Source Data Type: C - ASCII 1 Sample A - ASCII 32 Samples F - Float 32 Samples I - Integer 64 Samples \$ - Command Data
		Device Number (ASCII)	16	0	Example: Device number 25
			17	2	
			18	5	
		(ASCII)	19	,	Comma-separator
		(ASCII)	20	S	S for Sample Rate
		Sample Rate (ASCII)	21	3	Example : 32 Hz
			22	2	
		(ASCII)	23	,	Comma-separator
		(ASCII)	24	B	B for Battery Status
		Battery Status (ASCII)	25	G	G - Good Battery Voltage L- Low Battery Voltage B - Bad Battery Voltage
			(ASCII)	26	
		Year (ASCII)	27	2	The Year when the first sample was taken
			28	0	
			29	1	
			30	6	
		(ASCII)	31	-	
		Year (ASCII)	32	0	The Month when the first sample was taken
			33	9	
		(ASCII)	34	-	
		Day (ASCII)	35	1	The Day when the first sample was taken
			36	4	
		(ASCII)	37	T	
		Hour (ASSII)	38	1	The Hour when the first sample was taken
			39	9	
		(ASCII)	40	:	
		Minute (ASSII)	41	4	The Minute when the first sample was taken
			42	2	
		(ASCII)	43	:	

			Second (ASSII)	44	3	The First sample is when the second started
				45	8	
			(ASCII)	46	,	Comma-separator
			(Hex)	47	0x00	
			Sample Number 1 value in meters (Float - Little Endian)	48	0xF3	Example value 99.9999 meters (+Full Scale value)
				49	0xFF	
				50	0xC7	
				51	0XC2	
			Sample Number 2 value in meters (Float - Little Endian)	52	0xF3	Example value -99.9999 meters (-Full Scale value)
				53	0xFF	
				54	0xC7	
				55	0XC2	
			Sample Number 32 value in meters (Float - Little Endian)	172	0xF3	Example value -99.9999 meters
				173	0xFF	
				174	0xC7	
				175	0XC2	
Checksum			176	0xCA	Example only, not valid value	

Command Format send to the Data logger

	Frame Fields		Offset	Example	Description	
API Packet	Start Delimiter		0	0x7E		
	Length		MSB 1	0x00	Number of bytes between the length and the checksum	
			LSB 2	0xEF		
	Frame - specific Data	Frame Type		3	0x10	
		64-bit Destination Address		MSB 4	0x05	Set to the 64-bit address of the destination device. The following addresses are also supported: 0x0000000000000000 - Reserved 64-bit address for the coordinator. 0x000000000000FFFF - Broadcast address
				5	0x51	
				6	0xBA	
				7	0x5E	
				8	0x16	
				9	0x09	
10				0x14		

				LSB 11	0x01		
		16-bit Source Network Address		MSB 12	0x41	16-bit address of sender	
				LSB 13	0x41		
		Receive Options		14	0x01	0x01 - Packet Acknowledged 0x02 - Packet was a broadcast packet 0x20 - Packet encrypted with APS encryption 0x40 - Packet was sent from an end device (if known)	
		Broadcast radius		15	0x00	Sets maximum number of hops a broadcast transmission can occur. If set to 0, the broadcast radius will be set to the maximum hops value.	
		Options		16	0x00	Bitfield of supported transmission options. Supported values include the following: 0x01 - Disable ACK 0x20 - Enable APS encryption (if EE=1) 0x40 - Use the extended transmission timeout for this destination	
		Transmit Command Data	Command Data Type (ASCII)		17	R	Command Type: # - Commands to sensors ports All other Commands Example: Read Serial Number
			Command Type ASCII		18	D	
			Carriage Return		19	0x0D	
			Line Feed		20	0x0A	
Checksum			21	0xCA	Example only, not valid value		

Returned Acknowledge from the Data Logger

	Frame Fields		Offset	Example	Description	
API Packet	Start Delimiter		0	0x7E		
	Length		MSB 1	0x00	Number of bytes between the length and the checksum	
			LSB 2	0xEF		
	Frame - specific Data	Frame Type		3	0x90	
		64-bit Destination Address		MSB 4	0x05	Set to the 64-bit address of the destination device. The following addresses are also supported:
				5	0x51	
6				0xBA		

			7	0x5E	0x0000000000000000 - Reserved 64-bit address for the coordinator. 0x000000000000FFFF - Broadcast address	
			8	0x16		
			9	0x09		
			10	0x14		
			LSB 11	0x01		
		16-bit Source Network Address	MSB 12	0x41	16-bit address of sender	
			LSB 13	0x41		
		Receive Options		14	0x01	0x01 - Packet Acknowledged 0x02 - Packet was a broadcast packet 0x20 - Packet encrypted with APS encryption 0x40 - Packet was sent from an end device (if known)
		Broadcast radius		15	0x00	Sets maximum number of hops a broadcast transmission can occur. If set to 0, the broadcast radius will be set to the maximum hops value.
		Options		16	0x00	Bitfield of supported transmission options. Supported values include the following: 0x01 - Disable ACK 0x20 - Enable APS encryption (if EE=1) 0x40 - Use the extended transmission timeout for this destination
		Received Sensor Data	Source Data Type (ASCII)	17	\$	Source Data Type: F - Float 32 Samples \$ - Command Data
			Command Type ASCII	18	R	Example: RD Read Serial number Acknowledgr
				19	D	
(ASCII)	20		,	Comma-separator		
Returned	21		0	Example: 21-03-27-001		
Carriage Return	40		0x0D			
Line Feed	41	0x0A				
Checksum		42	0xCA	Example only, not valid value		

Enter RX to read the Device Number (1 to 255).
Enter RH to read the Part number.
Enter RD to read the Serial number.

Enter RK to read the Software version.
Enter RI to read the Burst Interval.
Enter RN to read the New File Interval.
Enter RL to read the Burst Length.
Enter RR to read Start Time Enable Status (1=yes 2=no).
Enter RQ to read the Start Time and Date minus 1 minute (YY-MM-DDThh:mmZ).
Enter RT to read the Time and Date (YY-MM-DDThh:mm:ssZ).
Enter RJ to read GPS Time Sync (1=on & 2=off).
Enter RV to read the Battery Voltage.
Enter RE to read the Battery Current.
Enter RZ to compare Time.
Enter RB to read the Streaming Out control.
Enter RM to read the Com Port Power control.

Enter WL,?? to write the Burst Length (1 to 59 Minutes, 0 for Continuous).
Enter WI,?? to write the Burst Interval (1 to 60 Minutes).
Enter WN,?? to write the New File Interval (1 to 60).
Enter WB 0b???????? to write the Streaming Out control.
Enter WM 0b???????? to write the Com Port Power control.
Enter WR,? to write Start Time enabled (1=yes & 2=no).
Enter WQ,YY-MM-DDThh:mm to write New Start Time and Date.
Enter WT,YY-MM-DDThh:mm:ss to write New Time and Date.
Enter WJ to write GPS Time Sync (1=on & 2=off).

Enter OF to read the active file number.
Enter OI to read the file size.
Enter ON to Start a new active file.
Enter OO,???? to open a file for reading.
Enter OR to Read next sector.
Enter OA to read sector.
Enter OC to close the open file.
Enter ZS,YY-MM-DDThh:mm:ss,?? to sync RTC to PCs time +1 sec. ?? is 1/128 sec per count.
Enter BP is a Broadcast Command Power On.
Enter LB to link Local to Bluetooth Device ESC to quit, Bluetooth must be enable.

Enter #1P0RS to read Group 1 Sample rate.
Enter #2P0RS to read Group 2 Sample rate.
Enter #3P0RS to read Group 3 Sample rate.
Enter #4P0RS to read Group 4 Sample rate.
Enter #1P0RD to read Group 1 Device # 100 Type.
Enter #1P1RD to read Group 1 Device # 106 Type.
Enter #1P2RD to read Group 1 Device # 112 Type
Enter #1P3RD to read Group 1 Device # 118 Type
Enter #2P0RD to read Group 1 Device # 124 Type.
Enter #2P1RD to read Group 1 Device # 130 Type.
Enter #2P2RD to read Group 1 Device # 136 Type
Enter #2P3RD to read Group 1 Device # 142 Type
Enter #1P0RB to read Group 1 Device # 100 Baud Rate.
Enter #1P1RB to read Group 1 Device # 106 Baud Rate.
Enter #1P2RB to read Group 1 Device # 112 Baud Rate
Enter #1P3RB to read Group 1 Device # 118 Baud Rate

Enter #2P0RB to read Group 1 Device # 124 Baud Rate.
Enter #2P1RB to read Group 1 Device # 130 Baud Rate.
Enter #2P2RB to read Group 1 Device # 136 Baud Rate
Enter #2P3RB to read Group 1 Device # 142 Baud Rate
Enter #1P0RL to read Group 1 Device # 100 Sync Staff Length.
Enter #1P1RL to read Group 1 Device # 106 Sync Staff Length
Enter #1P2RL to read Group 1 Device # 112 Sync Staff Length
Enter #1P3RL to read Group 1 Device # 118 Sync Staff Length
Enter #2P0RL to read Group 1 Device # 124 Sync Staff Length.
Enter #2P1RL to read Group 1 Device # 130 Sync Staff Length.
Enter #2P2RL to read Group 1 Device # 136 Sync Staff Length
Enter #2P3RL to read Group 1 Device # 142 Sync Staff Length
Enter #3PPORX to read Group 3 XBee Power State.
Enter #3PORE to read the XBee Coordinator's PAN ID. XBee power must be on!
Enter #4P0RR to read Group 4 Device # 201 Analog Input Range.
Enter #4P1RR to read Group 4 Device # 202 Analog Input Range.
Enter #4P2RR to read Group 4 Device # 203 Analog Input Range.
Enter #4P3RR to read Group 4 Device # 204 Analog Input Range.

To write a new value for the commands starting with the # change the R to W and add the new value.